

WORKTABLE WITH 5" BACKSPLASH & SLIDING DOORS

WORKTABLES - ENCLOSED BASE



MATERIALS

- 14 Gauge 304 Stainless Steel Top
- 18 Gauge Stainless Steel Body
- Enclosed With Stainless Steel Panels on Sides and Rear
- Stainless Steel Lower Shelf, Legs, and Bullet Feet

FEATURES

- Enclosed Cabinet Base
- Two Sliding Doors
- Adjustable Middle Shelf and Fixed Lower Shelf
- Adjustable Legs and Bullet Feet

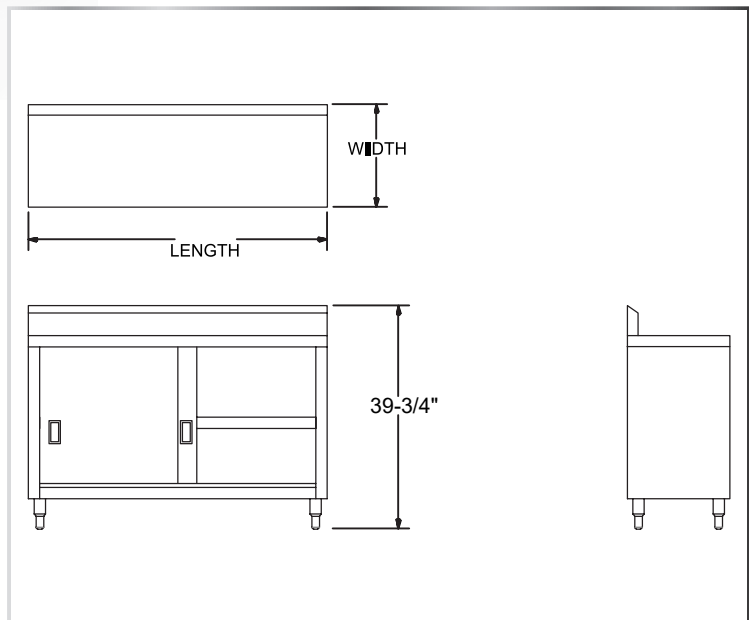

MODEL NUMBER	LENGTH	WIDTH
TCB-4824R5S	48"	24"
TCB-6024R5S	60"	24"
TCB-7224R5S	72"	24"
TCB-3630R5S	36"	30"
TCB-4830R5S	48"	30"
TCB-6030R5S	60"	30"
TCB-7230R5S	72"	30"