

HOT FOOD COUNTER WITH SEALED WELLS

NEW

FEATURES

- 12" x 20" Sealed Wells
- Individual Infinite Controls with Indicator Lights.
- 3/8" Thick x 8" Wide Poly Cutting Board.
- Adjustable Stainless Steel Legs
- 750W per well (240v).
- Both Models: NEMA plug 6-20



*Enclosed Base Model (HT-3SW-120B)

MATERIALS

- 20 Gauge 304 Stainless Steel
- Stainless Steel Feet

Add an Overshelf & Casters to your Hot Food Counter!
(See Pages 130)



*Top view of HT-4SW-240(B)

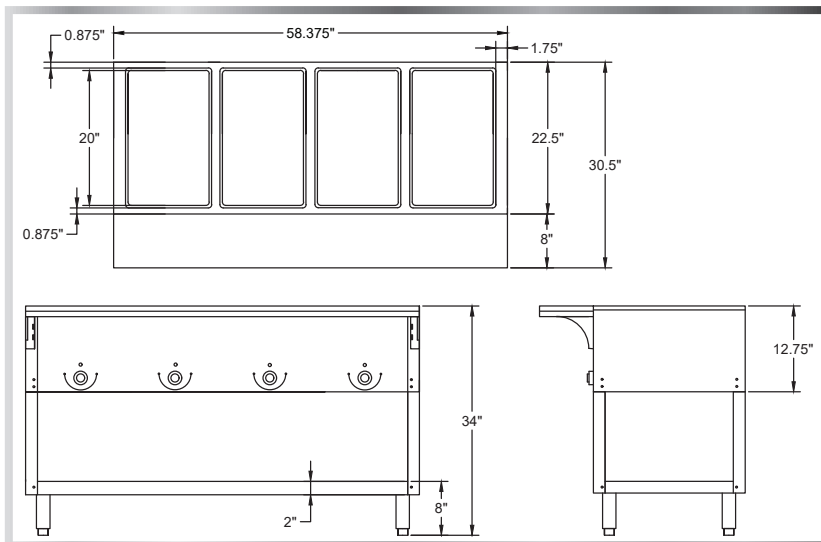

MODEL NUMBER	LENGTH	WIDTH
HT-3SW-240	44- ³ / ₈ "	30- ¹ / ₂ "
HT-3SW-240B	44- ³ / ₈ "	30- ¹ / ₂ "
HT-4SW-240	58- ³ / ₈ "	30- ¹ / ₂ "
HT-4SW-240B	58- ³ / ₈ "	30- ¹ / ₂ "